

[CONTRIBUTION FROM THE CHEMICAL LABORATORY OF THE UNIVERSITY OF ILLINOIS]

THE TEMPERATURE-ENTROPY DIAGRAMS FOR NITROGEN AND OXYGEN¹

BY WORTH H. RODEBUSH, JOHN W. ANDREWS AND JOHN B. TAYLOR

RECEIVED JULY 14, 1924

PUBLISHED FEBRUARY 5, 1925

The crystalline solid at absolute zero and the infinitely dilute gas are recognized to be unique conditions of matter and various generalizations have been made concerning the entropy and heat content of an element in these states. Similarly an element at its critical temperature and under its critical pressure is in a state which is equally unique. The heat content of an element at its critical point is a quantity which is of theoretical interest from the kinetic standpoint and it may very well be that the entropy may be found to have special significance. Likewise the whole temperature-entropy diagram² is of interest especially as there seem to be very few cases where the available data are of high accuracy over the entire range of temperature. All this, of course, is aside from the practical value that accurate thermal data on oxygen and nitrogen may have for air separation.

The direct method of obtaining the temperature-entropy diagram for a substance would be the determination of C_p , the heat capacity at constant pressure, for the liquid from the boiling point up to the critical point. C_p , however, changes with temperature and pressure and its value increases rapidly as we approach the critical point. If determinations are made on the liquid under its own vapor pressure, errors are introduced by partial vaporization and the complete, accurate determination of C_p for a substance is a very difficult task.

It occurred to the authors of this paper that a method might be devised for the measurement of the heat content of a liquid as a function of temperature and pressure, which would be analogous to the total heat determinations made for the determination of mean specific heats at high temperatures. When the total heat quantity measured is large, the errors due to heat leakage are minimized.

The application of a Joule-Thomson expansion to a super-heated liquid is such a method, for when a substance expands adiabatically and irreversibly its heat³ content is unchanged during the expansion. If the super-heated liquid is expanded to atmospheric pressure, its original heat content is readily calculated from the percentage vaporized on expansion.

¹ This paper was presented in part before the Division of Physical and Inorganic Chemistry at the Washington Meeting of the American Chemical Society, April, 1924.

² See Ewing, *Phil. Mag.*, 39, 633 (1920).

³ Lewis and Randall, "Thermodynamics," McGraw-Hill Book Co., N. Y., 1923, p. 67.

Since adiabatic conditions are more easily obtained at low temperatures the measurements were begun on oxygen and nitrogen.

Experimental.—The apparatus is shown diagrammatically in Fig. 1.

The principal part of the apparatus was the double-chambered Dewar tube A made of brass tubing. The outer tube is 3.75 cm. in diameter, 42 cm. long and the wall 0.75 mm. thick. The inner tube was 2.5 cm. in diameter and 0.3 mm. thick. The upper and lower chambers were, respectively, 23 and 10 cm. deep. All joints were soldered. In operation the apparatus was placed in a large Pyrex Dewar tube which

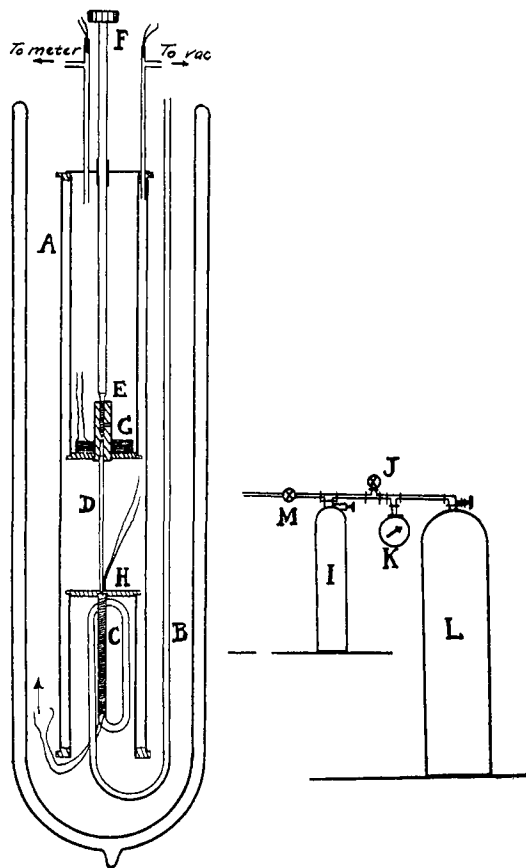

Fig. 1.—Apparatus.

In operation the liquid under constant pressure and heated to a constant temperature as shown by the thermocouple at H flowed through the german silver capillary and was throttled by the needle valve at E. Since the heat conductance of the german silver tube is quite negligible, this constitutes an adiabatic and irreversible expansion and is a considerable improvement mechanically over the "porous plug" formerly used in Joule-Thomson effect experiments. A series of baffles (not shown in the drawing) on the valve stem E retained the liquid while the vapor, of course, flowed out through the meter.

When the flow had been brought to a steady state by adjustment of the needle valve

was filled to a suitable depth with liquid air. The gas supply was in the tanks, L and I, K being the pressure gage. The gas was brought in at constant pressure through the copper tube B. C was a heating coil wound on the copper tube in the air space formed by the inverted chamber. By means of this coil the liquid (the gas was condensed by the liquid air) could be super-heated to any desired temperature. The liquid was conducted from the lower to the upper chamber by a german silver tube 0.5 mm. in diameter, 5 cm. long and with thin walls. This capillary ended in an expansion joint made of a spiral of copper tubing, which was closed at the end by the needle valve E. G was a heating coil. A vacuum was produced between the inner and outer tubes by a connection to a mercury vapor pump. The upper chamber was connected directly to an ordinary gas meter which read cubic feet in ten thousandths. One thermocouple was attached to the german silver capillary at H and another (not shown in the drawing) to the bottom of the upper chamber.

and heating coil C, the accumulated liquid was rapidly boiled out of the upper chamber by a current through the heating coil G. The disappearance of the liquid was sharply indicated in two ways; by a change in the rate of flow of gas through the meter and by a sudden rise in temperature of the upper thermocouple. At the instant the liquid disappeared the meter was read and the flow continued for five to ten minutes. At the end of that time the needle valve was closed, the pressure in B released (to avoid leakage through the needle valve) and the rate of evaporation of the liquid from the upper chamber taken by reading the gas meter at one-minute interval in order that a correction might be made for the evaporation due to heat leak. When the rate was determined the remaining liquid was boiled out by sending a current through the heating coil and the relative volumes of vapor and liquid on throttling were obtained. Data for a sample run on oxygen follow.

The temperature was 110° and the pressure 49.7 atm. Meter readings in cubic feet: at the beginning, 0.0907; at the end of ten minutes (needle valve closed), 0.1892; final reading, 0.6071. Rate of evaporation, 0.0002 cu. ft. per min. Total volume of gas passed through, 0.5164 cu. ft. (about 0.5 mole); volume of vapor, 0.0965 cu. ft. (after correcting for heat leak). Hence the percentage of vapor was 18.69.

Accuracy.—The rate of evaporation is due to heat conducted along the walls of the inner tube. With nitrogen it was necessary that the top of the apparatus be covered with liquid air in order to make the rate of evaporation small. With oxygen, on the other hand, it was necessary to keep the liquid-air level lower in order to avoid a negative rate of evaporation, since oxygen boils considerably above liquid-air temperature.

The rate was always definite, uniform and small, so that it could be corrected for without appreciable error. No correction was made for heat losses from or along the capillary tube. The radiation from clean metal surfaces is very small at low temperatures. A good vacuum (10^{-4} mm.) was maintained and calculations showed the conductivity of the german silver tube and of the liquid itself to be inappreciable.

The pressure was easily maintained very constant by means of the auxiliary pressure cylinder I. The gage used was calibrated against an absolute pressure gage. It was accurate to 0.3 atm.

The temperatures were measured by copper-constantan thermocouples which had been calibrated⁴ against the boiling point of oxygen, the sublimation point of carbon dioxide and the freezing point of mercury. In addition, it was always possible to check the upper thermocouple against the boiling points of oxygen and nitrogen. It is believed that the temperature measurements are not in error by more than 0.2 – 0.3° at any point.

Since it was the relative volumes with which we were concerned it was only necessary that the gas meter remain at constant temperature and read uniformly. The nitrogen used was the ordinary commercial product in cylinders and showed less than 1% of impurities. It contained, of course, a small amount of argon. The oxygen was manufactured electrolytically and was purchased as 99% pure. Actually it showed on analysis only

⁴ See Rodebush, *THIS JOURNAL*, 45, 1414 (1923).

about 98% of oxygen, the rest being nitrogen. The results on oxygen have been corrected for this nitrogen content by assuming that each gas would behave as though the other were not present. This cannot lead to serious error.

Both gases were passed over fused potassium hydroxide to remove carbon dioxide and water.

Results.—The regular runs were all made with the gas under its critical pressure. The percentage of vapor on throttling to one atmosphere was determined for the liquid at temperatures ranging from the boiling point up to the critical point. The heat content relative to the heat content at the boiling point at one atmosphere is given by multiplying the heat of vaporization by the fraction vaporized. The heat content of the liquid at its boiling point but under its critical pressure was calculated by means of the formula⁵

$$\left(\frac{\partial H}{\partial p}\right)_T = V - T \left(\frac{\partial V}{\partial T}\right)_p \quad (1)$$

This gives us the heat content of the liquid at constant pressure and ranging from the boiling point to the critical point. Since

$$dS = \frac{dH}{T} \quad (2)$$

we have only to plot heat content as abscissa against the reciprocal of the absolute temperature as ordinate and take the area under the curve to get the entropy at any temperature relative to the entropy of the liquid at its boiling point under its critical pressure. It remains to calculate the entropy of the liquid at each temperature under its own vapor pressure. We can do this by the approximation

$$\int_{p_1}^{p_2} \left(\frac{\partial S}{\partial p}\right)_T dp = - \left(\frac{\partial V}{\partial T}\right)_p \Delta p \quad (3)$$

Since $\left(\frac{\partial V}{\partial T}\right)_p$ becomes large as Δp becomes small this correction remains nearly constant and is equal to about 0.2 entropy unit for both oxygen and nitrogen.

The accompanying data were obtained by working at the critical pres-

⁵ From the densities of oxygen and nitrogen as a function of the temperature [measured by Kammerlingh Onnes [(a) *Proc. Amsterdam Acad.*, 13, 939 (1911); (b) 17, 953 (1915)] we calculate

$$\frac{dV}{dT} = \left(\frac{\partial V}{\partial T}\right)_p + \left(\frac{\partial V}{\partial p}\right)_T \frac{dp}{dT}$$

We do not know $\left(\frac{\partial V}{\partial p}\right)_T$ for either nitrogen or oxygen in the liquid state but in the case of liquid carbon dioxide the last term of the equation above is always small compared to the second term. We shall assume, therefore, that

$$\frac{dV}{dT} = \left(\frac{\partial V}{\partial T}\right)_p$$

Since the correction is small anyway, the error cannot be serious.

sure 33.49 amtospheres for nitrogen and 49.71 atmospheres for oxygen.⁶ Several runs were made at each temperature and the percentages of vapor obtained did not vary in general by more than 1 unit in different runs. Near the critical temperature where a small difference in the temperature of the liquid entering the capillary would cause a large difference in the percentage vaporized, there was, of course, more variation. The temperature of the entering liquid was controlled by the operator by varying the heating current in the coil C by means of a slide rheostat while he followed

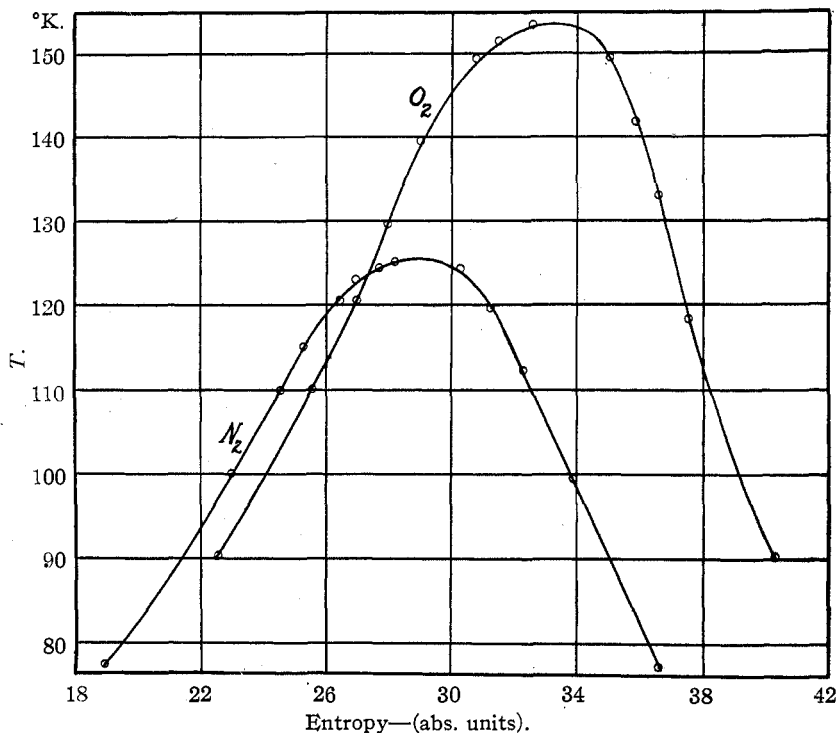

Fig. 2.—Temperature entropy diagram for oxygen, nitrogen.

the temperature with the thermocouple at H. The limits of constancy of temperature control depended only upon the patience of the operator. By making a large number of runs it was possible to select some during which the temperature control had been very close. In general we were satisfied if the temperature did not fluctuate by more than 0.2–0.3° during a run. This is undoubtedly the chief source of the variation in our results. In addition to the accompanying data, a large number of runs were made under conditions which were not deemed entirely satisfactory. The data from these runs, however, all tend to confirm the published data.

⁶ Ref. 5 b, p. 950.

TABLE I
EXPERIMENTAL DATA FOR LIQUID NITROGEN

T, °K.	—% Vapor: individual determinations—				Av.	Heat content cal. per mole relative to N ₂ liq. at 77.4°K. and 1 atm.	Entropy abs. unit per mole
100	27.10	27.09	...	27.10	370	23.0	
110	37.73	37.37	37.40	37.50	512	24.55	
115.2	43.66	44.18	44.16	44.00	600	25.30	
120.3	53.11	54.46	53.41	53.66	731	26.45	
123.2	58.61	59.26	...	58.93	802	27.05	
124.2	61.85	61.73	...	61.64	840	27.35	
125.2	70.98	69.83	...	70.40	960	28.10	
125.96	Calcd. 78.6	1072	29.0	

The values used for heats of vaporization, 1363 cal. at 77.4°K. for nitrogen and 1599 cal. at 90.1°K., are those given by Eucken.⁷ The heat contents in Tables I and II are for the liquid under the critical pressure while the entropies are for the liquid under its own vapor pressure.

TABLE II
EXPERIMENTAL DATA FOR LIQUID OXYGEN

T, °K.	—% Vapor: individual determinations—					Av.	% Vapor corr. for N ₂ content	Heat content cal. per mole relative to O ₂ liq. at 90.1°K. and 1 atm.	Entropy abs. units per mole
110	18.87	18.64	18.69	...	18.73	18.37	294	25.60	
120.3	28.33	27.68	28.65	29.06	28.43	28.13	454	26.90	
125.2	31.66	31.71	33.10	...	32.41	31.70	506	27.40	
129.8	36.23	37.40	37.43	36.74	36.97	35.70	572	27.90	
139.5	45.65	46.44	46.18	46.25	46.13	45.10	720	29.00	
149.4	61.25	63.11	62.18	61.4	980	30.80	
151.5	69.34	67.43	68.38	...	68.38	67.6	1080	31.50	
153.3	83.59	75.37	79.93	...	79.63	79.2	1265	32.60	
154.27					Calcd. 86.8		1388	33.40	

For temperature-entropy diagrams at higher temperatures it is customary to take the entropy at 0° as the arbitrary zero of entropy. At low temperatures it seems logical to take the entropy as zero at absolute zero in accordance with the Third Law. The values used for the entropies at the boiling points, 22.55 for oxygen and 18.99 for nitrogen, are those of Lewis and Gibson.⁸

The Vapor Line.—If we had a satisfactory equation of state for nitrogen and oxygen as they approach the condition of saturated vapors, we could make use of the experimentally determined value for C_p and the relation

$$\left(\frac{\partial S}{\partial p}\right)_T = -\left(\frac{\partial V}{\partial T}\right)_p \quad (4)$$

to calculate the absolute entropy of the saturated vapor. These gases

⁷ Eucken, *Verh. deutsch. phys. Ges.*, 18, 4 (1916).

⁸ Lewis and Gibson, *THIS JOURNAL*, 39, 2571 (1917).

are far from perfect, however, and there appears to be no satisfactory equation of state in this region.

We can still use the exact thermodynamic relation

$$\frac{dp}{dT} = \frac{\Delta H}{(V - V_0) T} \quad (5)$$

to calculate the entropy of vaporization. Kammerlingh Onnes⁹ has measured the vapor pressures of oxygen and nitrogen and the densities of the coexisting phases at different temperatures for the two gases. From these data and Equation 5, above, we have calculated Tables III and IV.

TABLE III

NITROGEN

T, °K.	Heat of vaporization, cal. per mole	Entropy of vaporization	Absolute entropy of vapor
99.4	1090	10.97	33.90
111.9	829	7.40	32.25
119.5	617	5.17	31.30
124.5	351	2.74	30.25

TABLE IV

OXYGEN

T, °K.	Heat of vaporization cal. per mole	Entropy of vaporization	Absolute entropy of vapor
118.6	1282	10.8	37.50
132.9	1100	8.29	36.50
143.2	904	6.30	35.80
149.8	622	4.16	35.05

The Heat Content at the Critical State.—It is interesting to note that if either of these gases be expanded from its critical temperature and pressure to one atmosphere, a considerable amount of liquid will remain unevaporated. This means that the gas can be used as a refrigerant in a cycle between the critical temperature and the boiling point. By increasing the initial pressure the percentage of liquid would be greatly increased, since $\left(\frac{\partial S}{\partial p}\right)_T$ is a large quantity near the critical temperature.

The method we have described above can be readily adapted for use on substances at higher temperatures. Also, it can be used to determine the thermal properties of gases as well as liquids.

Summary

A satisfactory apparatus has been devised for the measurement of the heat contents of super-heated liquids.

The temperature-entropy diagrams of nitrogen and oxygen have been constructed.

URBANA, ILLINOIS

⁹ Onnes, *Proc. Acad. Sci. Amsterdam*, 17, 950, 959 (1915).